

Promotor

promotional displays



ORIGINAL PROMOTOR

ORIGINAL PROMOTOR designed many years ago and has been very successful in numerous different sales promotions, demonstrations and sampling projects. Sold worldwide it must be regarded as a first in its field.

- Produced with interchangeable top and bottom to allow for the umbrella.
- Single sided header also available.
- Both can be changed easily for use on the left or right hand side depending on the clients' requirements.
- Large bottom giving additional storage for promotional items.
- PVC coated nylon carry bag, complete with printed pictorial assembling instructions and tailored area for umbrella.

CLASSIC PROMOTOR

CLASSIC PROMOTOR a direct development from the Original Promotor.

- 'Foot well' shaped bottom with 'top hat' pole recesses for ease of moving the assembled unit.
- Standard, rigid or stiftop with a choice of one, two or no holes.
- Header panels with rounded corners and special hollow plastic self-adhesive fixings to the back so fixings are totally invisible from the front.
- Standard shape 3mm foam board headers complete or with fixings separate to allow printing direct onto panels before final despatch.
- Header fixings can be supplied only, so that you can produce foam board header panels to virtually any shape your client requires.
- New style simple to assemble roof kit, formed in 3mm foam board.





ORIGINAL PROMOTOR

CLASSIC PROMOTOR

Dimensions & Weights

WEIGHTS	Kg
Rigidtop/Stiftop.....	1.48
Top	1.15
Shelf.....	1.09
Bottom	0.96
Body Panel.....	4.63
Pole Set (six pieces) H	2.40
Header.....	0.72
Pole Set (six pieces) M Roof Kit	2.36
Roof Kit	1.78
Door Panel.....	0.85
Bag.....	1.40

PACKING

Individual Reusable Carton 1.00

External Measurements
920mm x 560mm x 150mm

Bulk packaging, dimensions and weight dependent on number of units required.

Weights and measurements quoted are approximate.

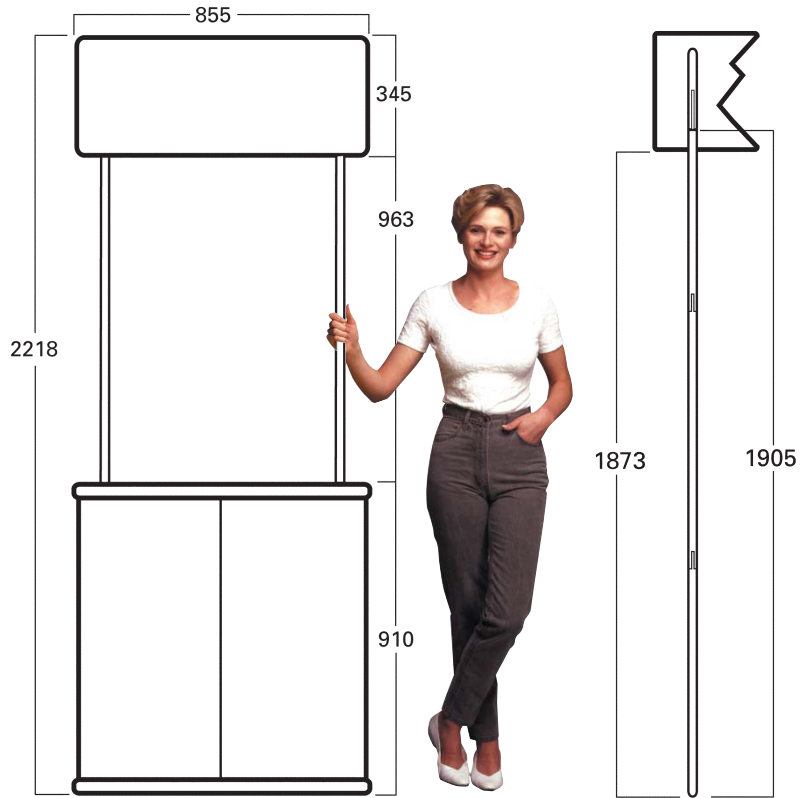

UNIT AND HEADER

POLES - H

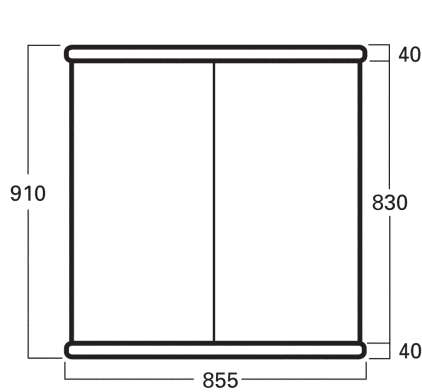

FRONT

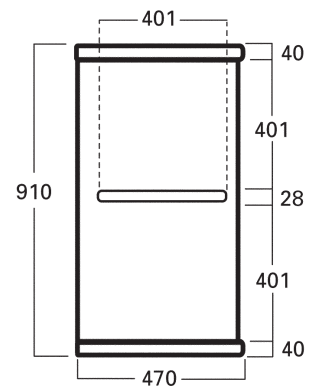

SIDE - ONE SHELF

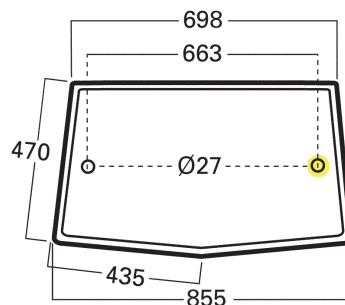

TOP / RIGIDTOP / STIFTOP

ORIGINAL ONE HOLE TOP

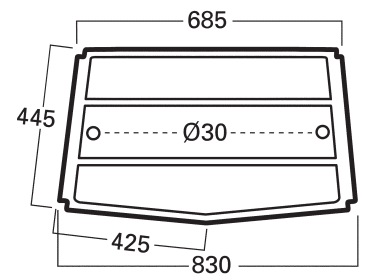

SHELF

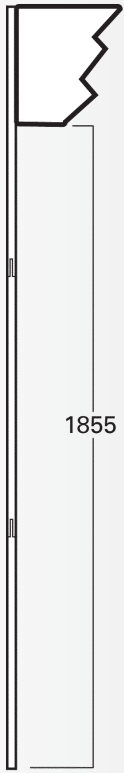

POLES M

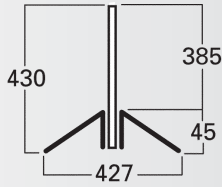

ROOF KIT

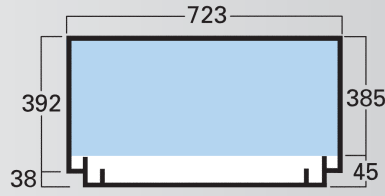

ROOF KIT HEADER
VISUAL GRAPHIC SIZE

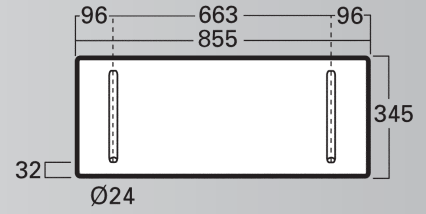

HEADER

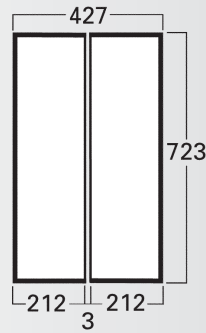

ROOF PANELS

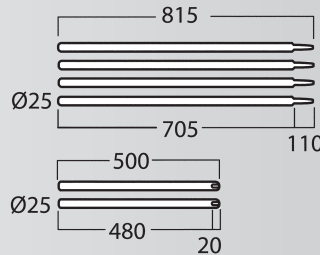

POLES - M
ROOF KIT STYLE

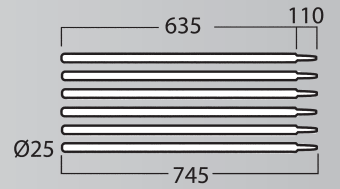

POLES - H

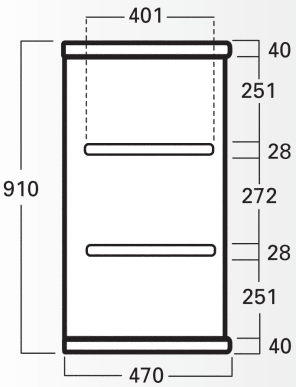

SIDE - TWO SHELVES

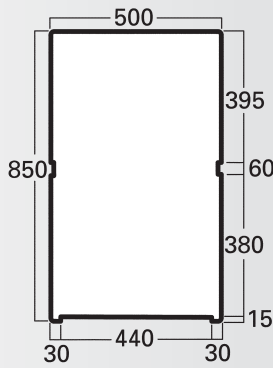

DOOR PANEL

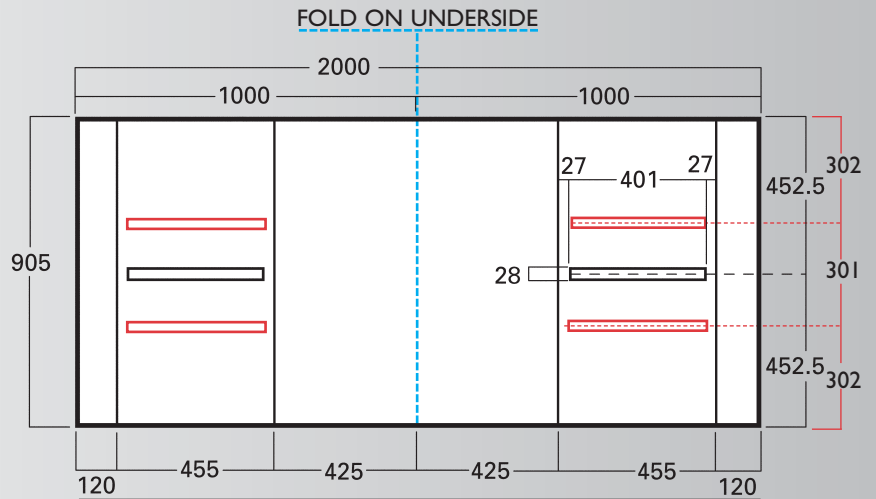

GRAPHIC SIZE FOR ONE AND TWO SHELF UNIT

ALLOW 37.5mm FOR TOP AND BOTTOM

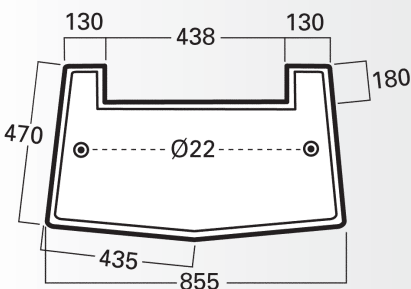

CLASSIC BOTTOM

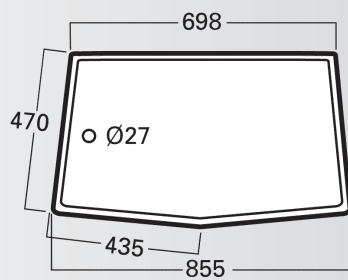

ORIGINAL TOP / BOTTOM

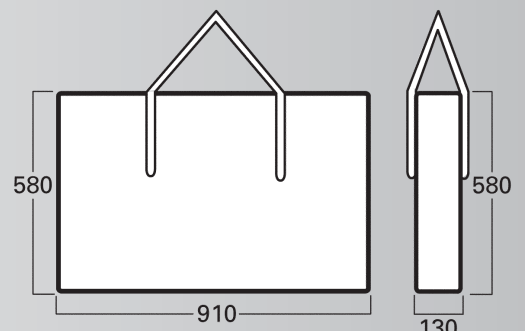

BAG

PROMOTOR ACTION

PROMOTOR ACTION has many interesting features over our other Promotors.

- 'Flat top' option, a really clever top which is totally flat.
- The 'flat top' enables the demonstrator to maintain a high degree of cleanliness for sampling food.
- This clever top also incorporates a membrane for maximised strength.
- Also available to assist in hygiene qualities a built in 'tidy bin' with attached hinged lid.
- Novel offset design to the top and front enables the use of standard poster to be attached for day to day change of special promotions without spoiling the graphic design.
- Promotor Action as with all of our products, packs with its accessories into its own easy to carry durable black nylon carry bag with printed assembly instructions.





PROMOTOR ACTION

Dimensions & Weights

WEIGHTS	Kg
Flat Top	3.95
Top	1.55
Shelf	1.35
Bottom	1.16
Body Panel	5.45
Tidy Bin (complete in shelf)	1.82
Pole Set (four pieces) C	2.12
Header	0.90
Round Tray	0.95
Bag	1.62

PACKING

Individual Reusable Carton..... 1.8
 External Measurements
 1050mm x 675mm x 200mm

Round Tray Carton.....0.45
 External Measurements
 523mm x 523mm x 83mm

Bulk packaging, dimensions and weight dependent on number of units required.

Weights and measurements quoted are approximate.

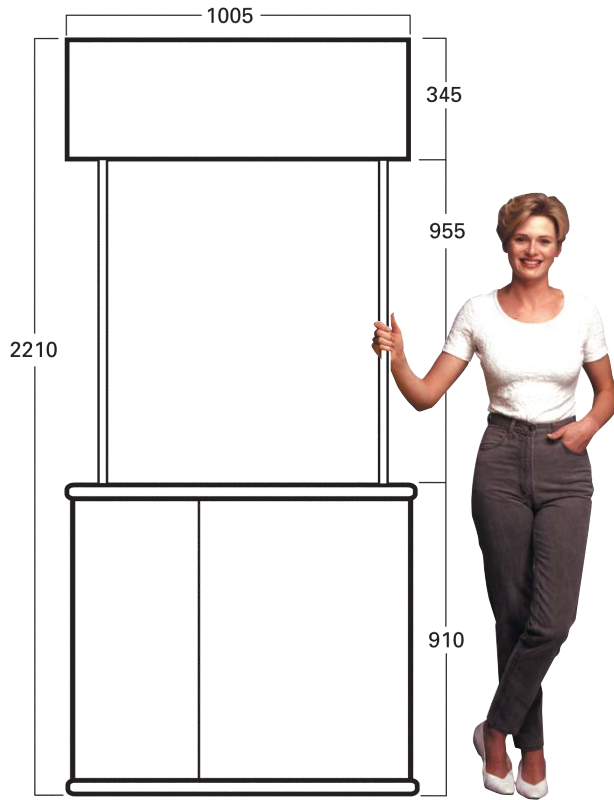

UNIT AND HEADER

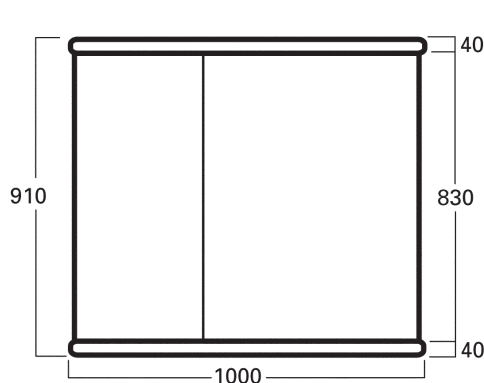

FRONT

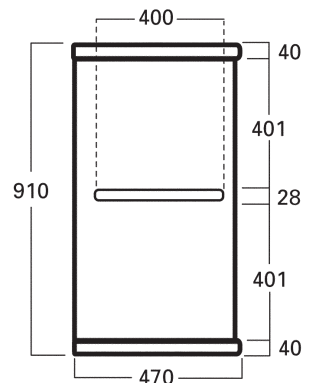

SIDE - ONE SHELF

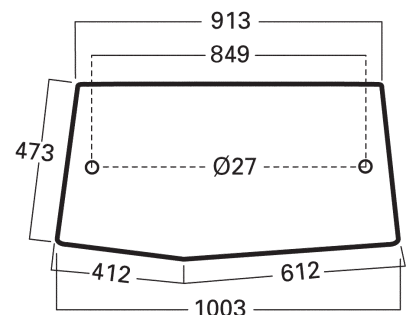

FLAT TOP



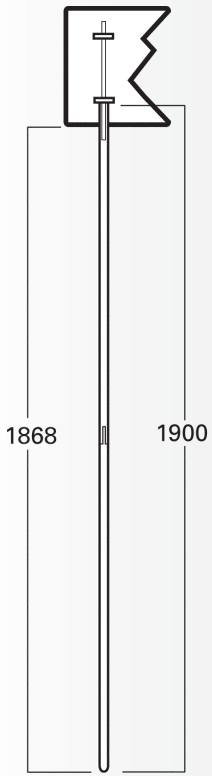

POLES - C

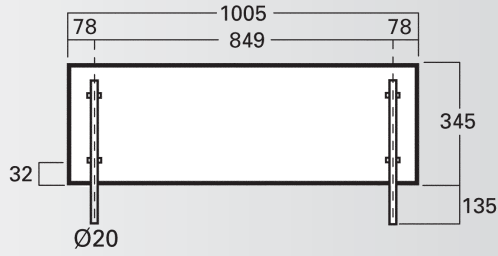

HEADER

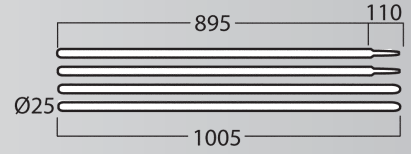

POLES - C

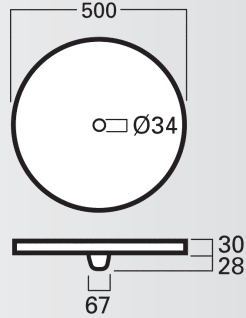

ROUND TRAY

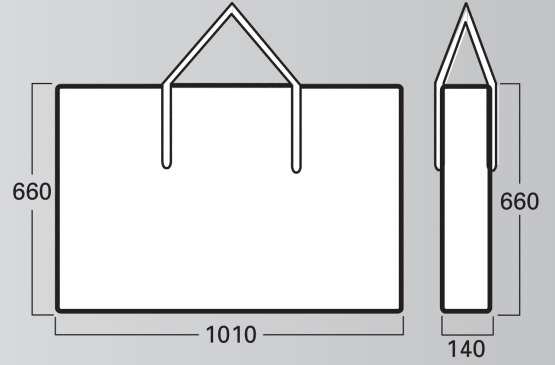

BAG

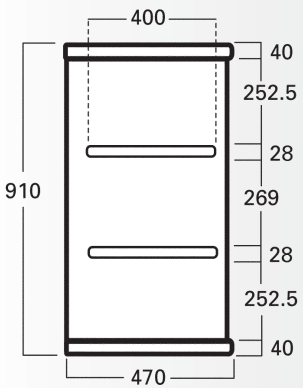

SIDE - TWO SHELVES

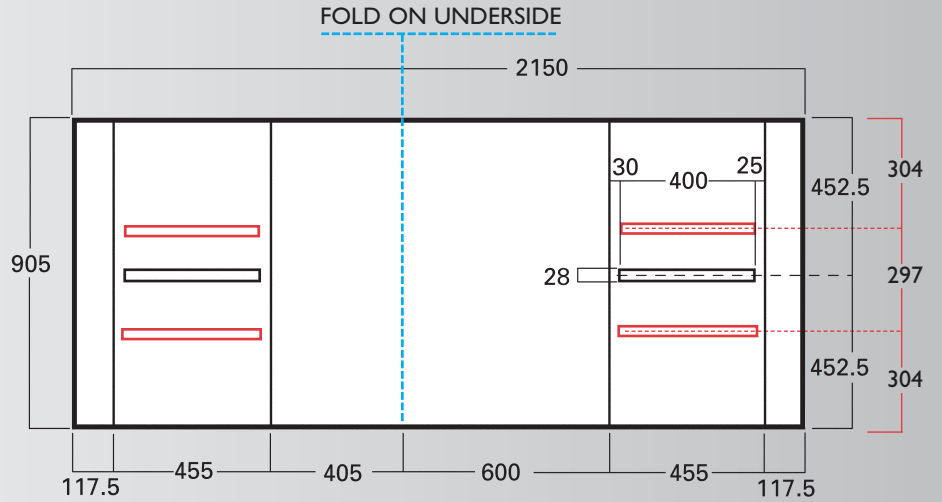

GRAPHIC SIZE FOR ONE AND TWO SHELF UNIT

ALLOW 37.5mm FOR TOP AND BOTTOM

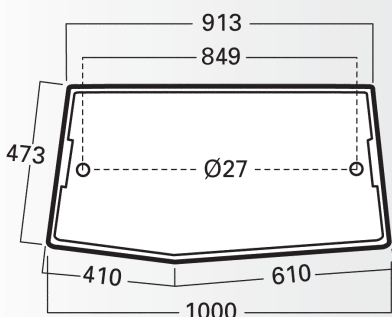

TOP

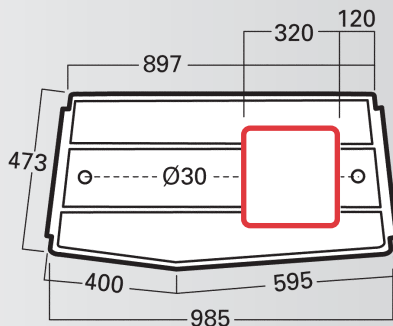

SHELF WITH BIN

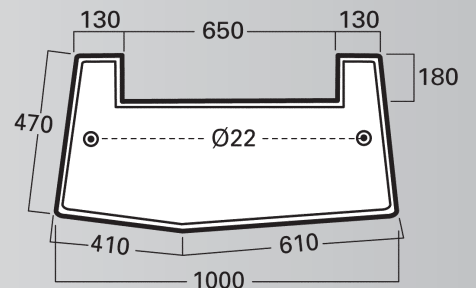

BOTTOM

Promotor Special Effects

Being the manufacturers of an extensive range of products and having up to date CNC technology we do have some flexibility when it comes to tailoring products such as:

- Reducing product height.
- Making products taller.
- Changing shelf positions.
- Adding openings in the front, sides or tops.
- Changing pole configurations.
- Changing header styles or sizes.
- Adapting bags to make larger or smaller.

Promotor Special Effects depends on client's exact requirements. For more information please telephone, fax or email and we can answer any questions on adapting products.



Examples of products tailored for special requirements

- Client application for Promotor Solus with cut out in top to be used as a portable dump bin.



- Adapted Solus to have board material for Body Panel which was used for direct print, meaning body panel was printed with digital flatbed technology.

- We created a special flat top for the Promotor Action which was clear so stamps could be viewed safely and easily for a large stamp exhibition.



- This product was a Merit special. The client required the same shape but the base on the floor and the shelf in the middle.

Set Up

- All Promotor displays have the same concept in hassle free set up.
- No tools required.
- Quality design and well thought out assembly.
- Top/Bottom lock into body panel for extra strength and hold.
- High quality steel poles connect easily giving quality finish.
- Headers and fixings fit cleanly and easily onto poles.
- Bags designed in high quality materials with sections for accessories and components.
- Minimum time on all products to assemble.





Headers and Fixings Options

ORIGINAL, CLASSIC, BONUS, MAXI, MINI, DEMO CENTER, BUDGET, MERIT AND COMPACT



3mm foam board with self-adhesive plastic hollow fixings.

ACTION AND PLUS



3mm foam board with plastic poles, clips and screwed through fixings.

CHAMPION



3mm foam board with self-adhesive plastic hollow fixings.

BONUS, POPULAR AND STANDALONE

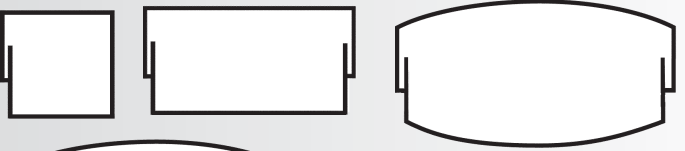

CLASSIC, BONUS, STANDALONE ROOF AND HEADER KIT



Double-sided 3mm foam board header panel for use with slotted poles.

Foam board is available with either round or square corners.

All types of fixings can be supplied separate to enable you to produce your own headers. Headers manufactured by us can be supplied in component form for assembly after printing. Header styles can be swapped between one product and another if required.

Individual Pole Sizes

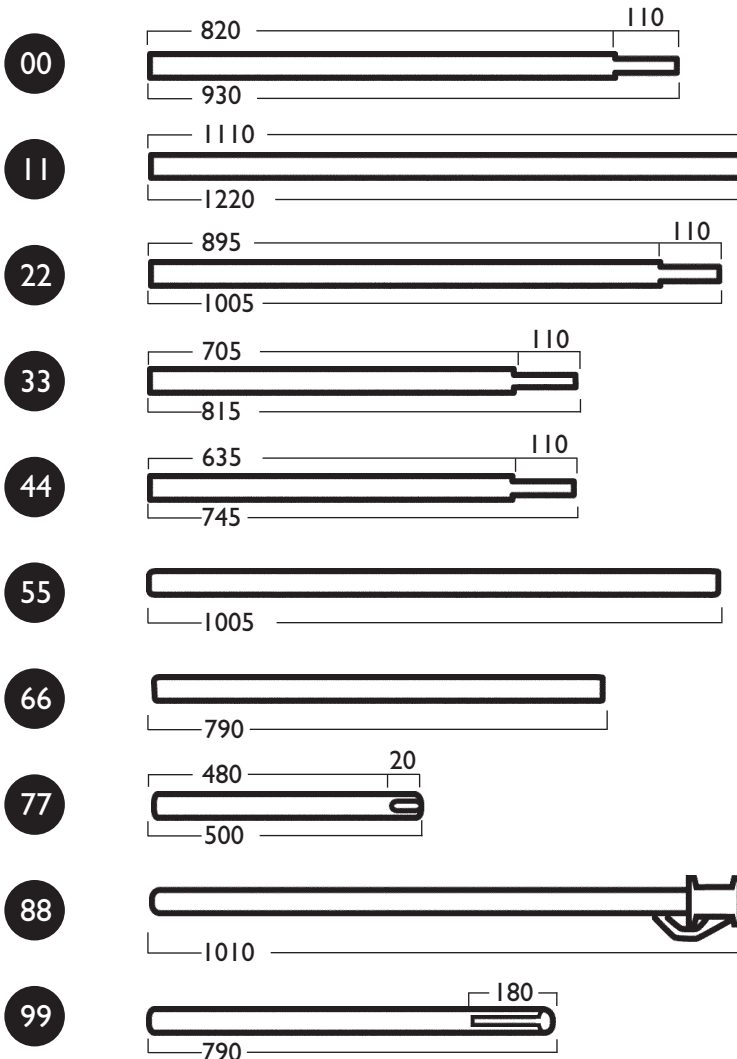

25mm diameter steel finished in black, white, silver grey or bright silver epoxy polyester powder.

Header Fixings

Plastic poles, clips and screw through fixings.

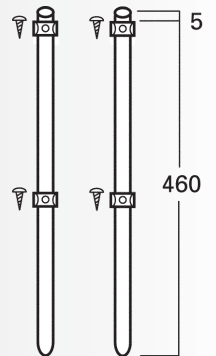

Self-adhesive plastic hollow fixings.

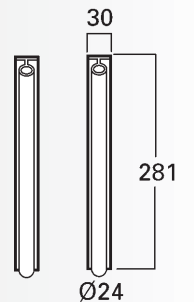

Round Tray

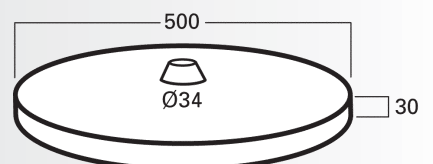

Round tray fixings.

Header and Pole Configurations

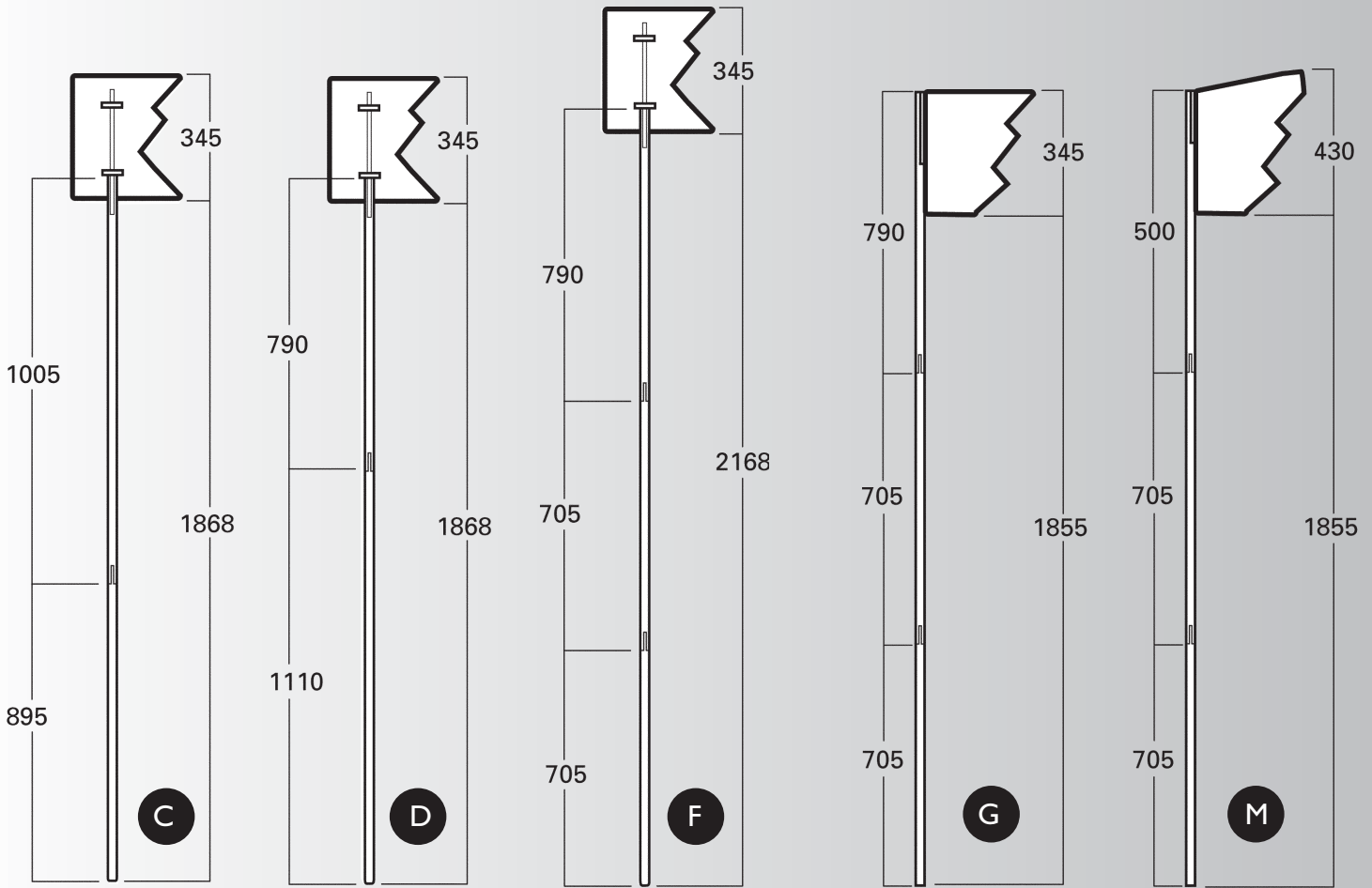

Single sided foam board headers with plastic poles, clips and screwed through fixings.

Double sided foam board headers with plastic poles, clips and screwed through fixings.

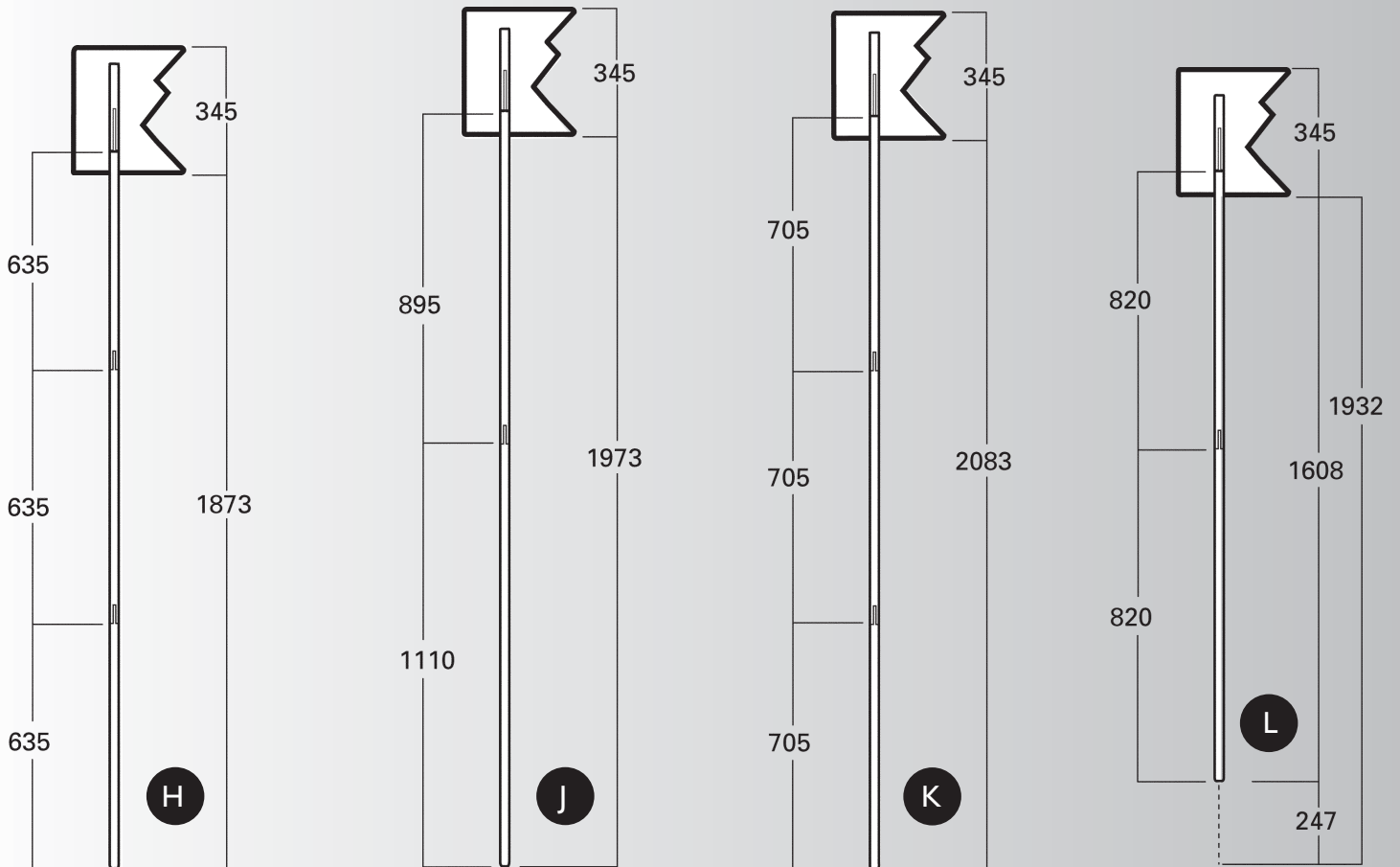

Single sided foam board headers with self-adhesive hollow plastic fixings.

Pole set raised from ground as poles sit on baseshelf.