



# NEW, EXCITING

direct from

# PROMOTOR

## Promotional Displays



**Swift Promotor 360,  
a very portable easy to  
assemble, free standing  
cost effective durable display**



Designed and manufactured by Promotor

**swift**  
**PROMOTOR**  
**360**

SWIFT PROMOTOR 360 our latest development in our range of Promotional Displays, ideal for free standing promotions, where all round graphics are required.

- Very durable and capable of holding weight.
- Flat packs easily into it's own tailor made carton.
- Reusable carton has dedicated graphic tube protecting the graphic, allowing graphics to be added without unpacking the product.
- Graphic easily wraps around display giving maximum effect.
- Smooth finish top cap is added after graphics have been applied to give quality finish, and allows extra strength.
- Two sizes available as standard stock items, tailored sizes available on request.
- Low cost product, with a high quality finish.
- Wood effect top and colours available on request.
- Black nylon carry bag available, including area for graphic tube to protect graphic wrap.



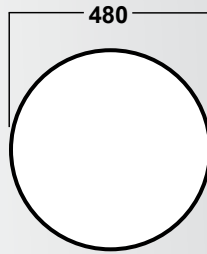

**TOP CAP**

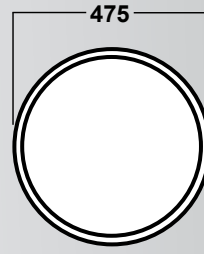

**INNER MOULDING**

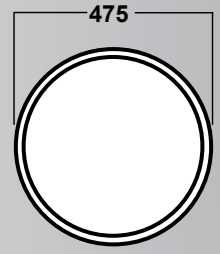

**BOTTOM MOULDING**

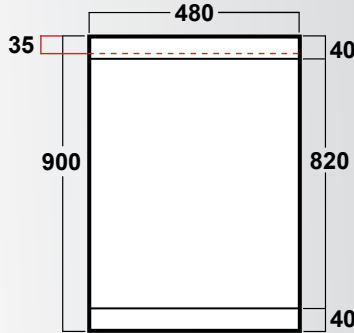

**COMPLETE UNIT  
(ONCE GRAPHICS  
ARE APPLIED)**

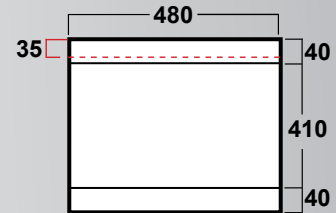

**COMPLETE UNIT  
SHORT UNIT**

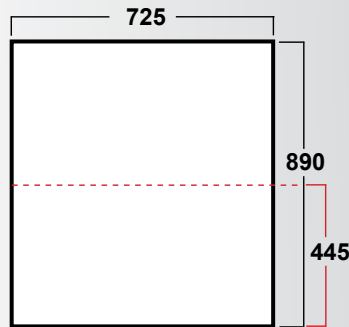

**BODY PANEL  
SHORT UNIT**

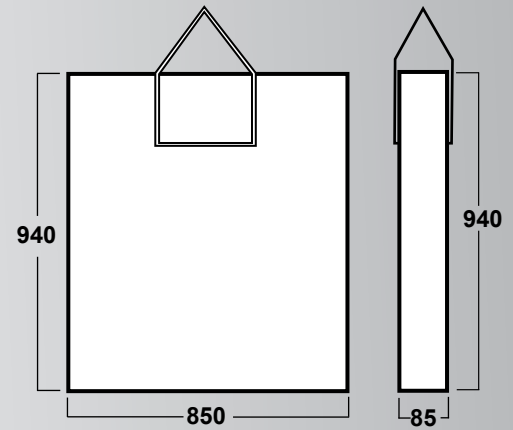

**BAG**

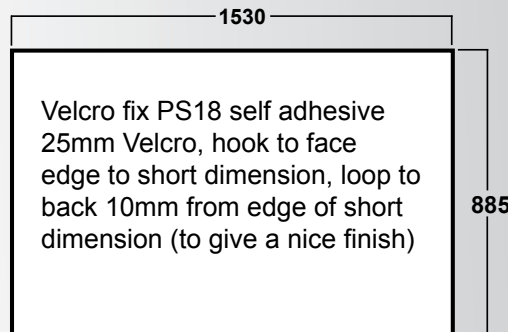

**GRAPHIC  
WRAP SIZE**

**Graphic visual site size  
1495mm x 865mm**

Graphic not supplied with product, recommended size (if different graphics are used measurements may vary)

